

Keys, Spanners, Wrenches

TORX keys

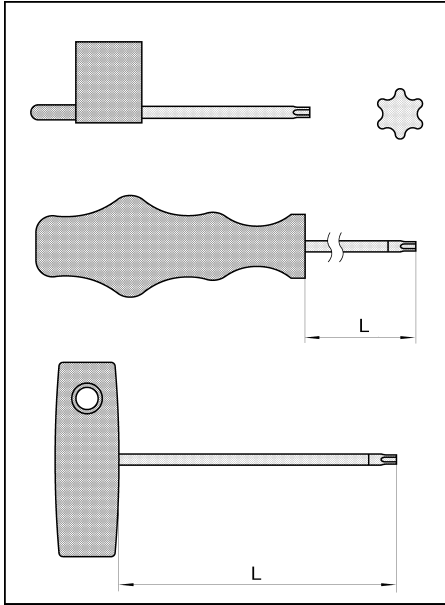

Size	L mm	Part-No.	PU	Price each
Key with flag				
T 7		39077-0-02507-1	5	4,00
T 8		39077-0-03008-1	5	4,00
T 9		39077-0-03009-1	5	4,00
T15		39077-0-04015-1	5	4,00
Key with handle				
T 8	60	39077-0-03008-2	1	6,30
T 9	60	39077-0-03009-2	1	6,30
T10	80	39077-0-03010-2	1	6,30
T15	80	39077-0-04015-2	1	6,30
T20	100	39077-0-00020-2	1	7,10
Key with T-handle				
T 9	100	39077-0-03009-3	1	11,90
T10	100	39077-0-03010-3	1	11,90
T15	100	39077-0-04015-3	1	14,10

Hexagon keys

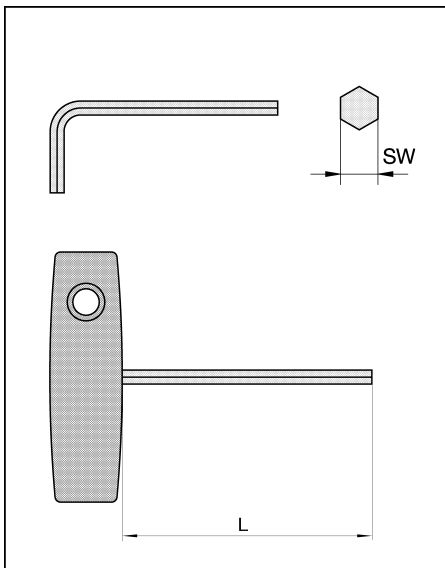

Size	L mm	Part-No.	PU	Price each
Allen key				
SW 2		39120-0-02000-0	5	1,20
SW 2,5		39120-0-02500-0	10	1,20
SW 3		39120-0-03000-0	5	1,20
SW 4		39120-0-04000-0	5	1,60
SW 5		39120-0-05000-0	5	1,60
SW 6		39120-0-06000-0	5	2,10
SW 8		39120-0-08000-0	5	3,10
SW 10		39120-0-10000-0	5	3,90
Key with T-handle				
SW 3	100	39140-0-00301-0	1	7,90
SW 3	150	39140-0-00302-0	1	7,90
SW 4	100	39140-0-00401-0	1	7,90
SW 5	100	39140-0-00501-0	1	7,90
SW 6	100	39140-0-00601-0	1	7,90
SW 8	100	39140-0-00801-0	1	7,90
SW 8	150	39140-0-00802-0	1	7,90
SW 10	100	39140-0-01001-0	1	7,90
SW 10	200	39140-0-01002-0	1	7,90

C-Spanners/Engineers' wrenches

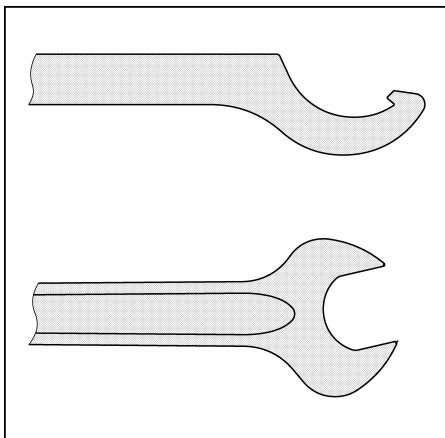

Size	For clamping nut	Part-No.	PU	Price each
C-Spanner				
40/42	M 30 x 1,5	39158-0-40421-0	1	9,50
45/50	M 40 x 1,5	39158-0-45500-0	1	10,80
58/62	M 48 x 2,0 and M 50 x 1,5	39158-0-58622-0	1	12,20
Engineers' wrench				
SW 13		39162-0-00013-0	1	2,10
SW 27		39162-0-00027-0	1	9,40
SW 33		39162-0-00033-0	1	17,00
SW 36		39162-0-00036-0	1	17,00
SW 41		39162-0-00041-0	1	17,00
SW 46		39162-0-00046-0	1	18,20
SW 60		39162-0-00060-0	1	52,00